

# HilhouT

# IERLAND

TYPE/TIPO/MODELE 280 - ART. NR./REF. 710067

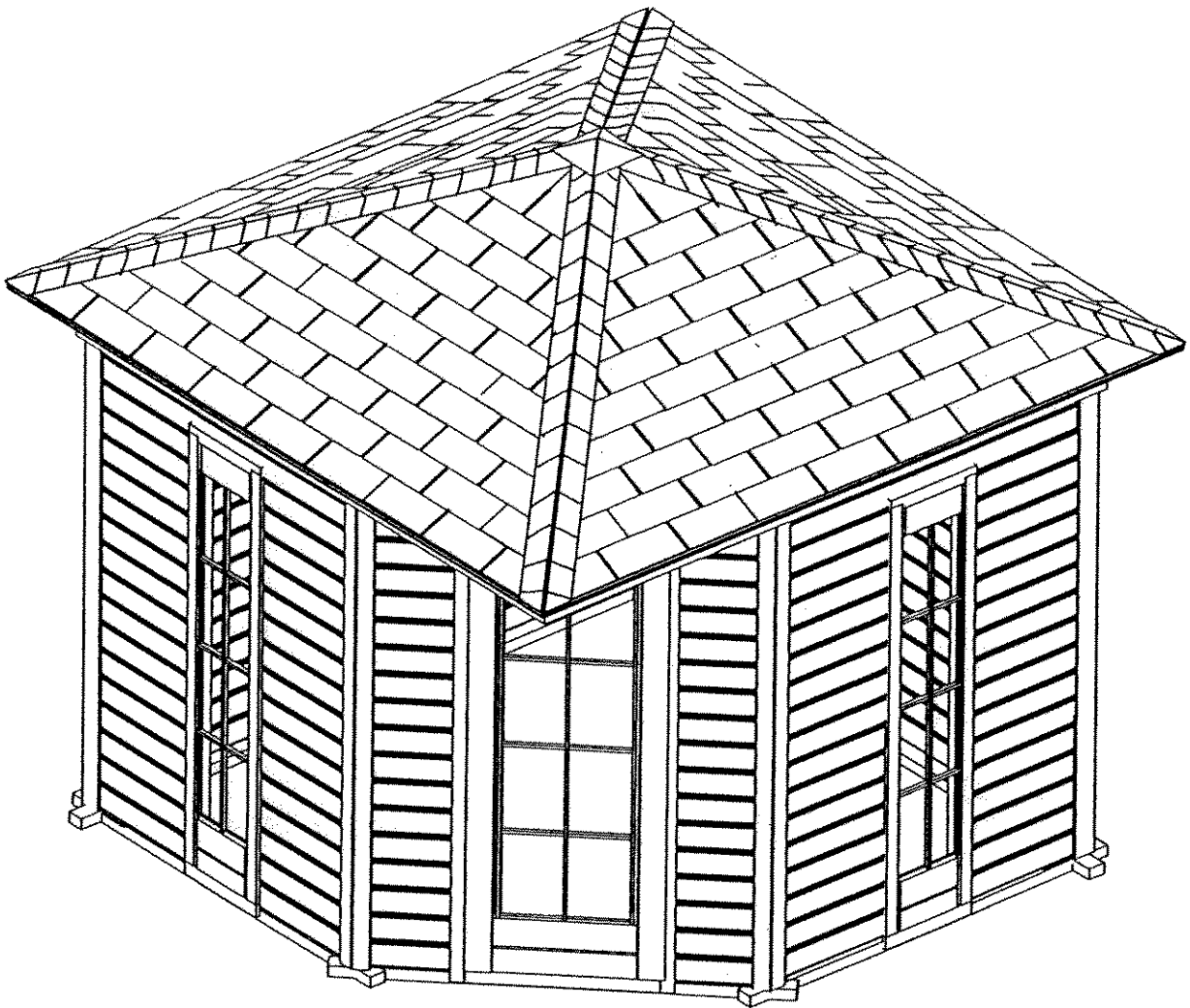

MONTAGE HANDLEIDING / MONTAGEANLEITUNG / NOTICE DE POSE

BUILDING INSTRUCTIONS / ISTRUZIONI PER IL MONTAGGIO / INSTRUCCIONES DE MONTAJE

## **F** Conseils importants:

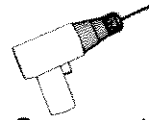

- Lisez tout d'abord cette notice d'un bout à l'autre.
- Pré percez autant que possible les assemblages à visser.
- Une bonne ventilation de la maisonnette est indispensable. Ouvrez régulièrement portes et fenêtres.
- Les maisonnettes Hillhout sont livrées non traitées.
- Le traitement, indispensable, peut intervenir soit avant, soit après le montage, aussi bien à l'extérieur qu'à l'intérieur.
- Il vous suffit de passer la lasure de votre choix; vous pouvez également la peindre; n'utilisez pas de laque ni de vernis. La peinture micro poreuse est conseillée.
- Il est normal que le bois travaille, vous pourrez éventuellement constater dilatations et rétrécissements en fonction des périodes de l'année.
- Si le montage est effectué par une température inférieure à 15°, nous vous conseillons de coller les plaques de shingle sur le toit.
- Appliquez un joint silicone pour éviter la pénétration de l'humidité entre la base et la fondation (avant ou après le montage).
- Si votre maisonnette est équipée d'un auvent, il faut poser le tuyau de la gouttière côté façade.
- Si vous désirez pendre la maisonnette, il faut retirer le verre de la porte et de la fenêtre (en enlevant les parecloses) pour peindre également la rainure. Appliquez un joint silicone sur les parecloses côté extérieur.
- Entretenez régulièrement la serrure.
- Montez la maisonnette en respectant le fil du bois, inversé pour chaque marche (voir dessin).







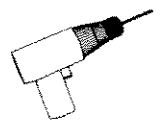

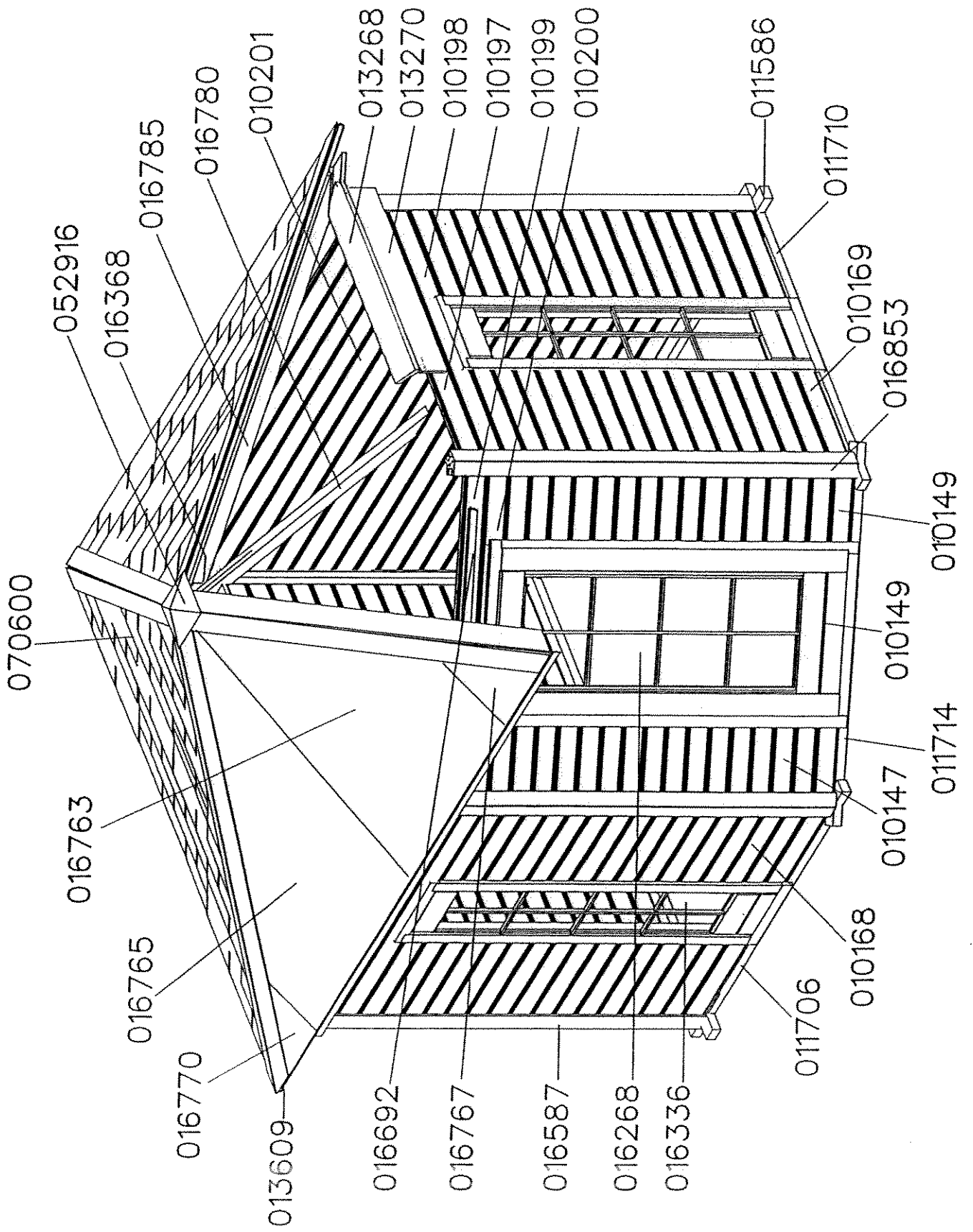

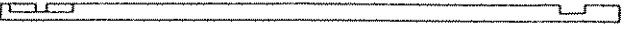



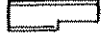
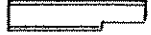
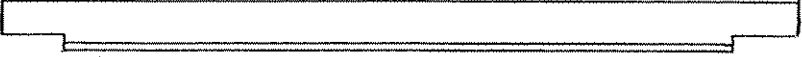
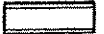





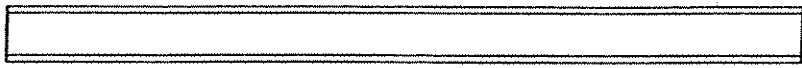



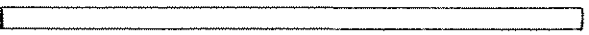

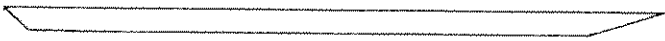
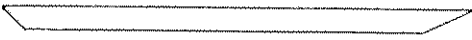

## **GB** IMPORTANT TIPS:

- Please read these building instructions carefully before building.
- The base/foundation for your cabin must be level and flat.
- Pre-drill as much as possible the holes for the screws (use the correct drill-size).
- Good ventilation of the log cabin is necessary (open door and/or window frequently).
- Hillhout log cabins are supplied UNTREATED. Before or after building we advise you to treat the timber first with a preservative ("impraline"). For more information, please contact your paint-specialist. You can then paint or stain your cabin, inside as well as outside with a moisture regulating product (don't paint over the latch and bolt + hinges). Don't use a lacquer as this will "close" the structure of the wood and humidity can't get out.
- To prevent humidity from entering between the foundation beams and your foundation, please put silicone-lute in between.
- Because of the natural working of wood, your log cabin can expand or shrink in height.
- Should you want to fit any shelves (for books, for instance), you can fix these to 2 wall logs at a maximum. Because of the working of the wood it will be better, however, to use a separate rack against the wall
- In the case of your log cabin having a front extension, the gutter's drain should be placed at the front wall.
- Please remove the glazing from door and window before painting, to be able to paint the rabbets as well. ATTENTION: turn window fully upwards in order to take it out of its frame and then carefully remove the glass! Apply silicone-lute to cover the space between the glass-laths and the glazing on the outside of the window.
- Frequently maintain the latch and bolt + hinges.
- Please build the log cabin walls alternating the position of the wood growth rings (see drawing).
- Your log cabin is a valuable possession. Please think of maybe having it insured.



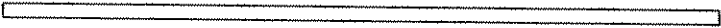

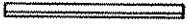
| art. nr./ref |             |  |    |
|--------------|-------------|--|----|
| 011710       | 1710 mm     |    | 1  |
| 011706       | 1710 mm     |    | 1  |
| 011714       | 1710 mm     |    | 1  |
| 011586       | 2790 mm     |    | 2  |
| 016853       | 2090 mm     |     | 2  |
| 016857       | 2090 mm     |     | 3  |
| 052924       | -           |  | 10 |
| 010149       | 335 mm      |     | 2  |
| 010169       | 540 mm      |     | 4  |
| 010203       | 2481 mm     |   | 2  |
| 010147       | 335 mm      |   | 30 |
| 010168       | 540 mm      |   | 60 |
| 010200       | 1464 mm     |  | 1  |
| 010199       | 1464 mm     |  | 1  |
| 010198       | 1430 mm     |  | 2  |
| 010197       | 1430 mm     |  | 2  |
| 010201       | 2481 mm     |  | 34 |
| 013270       | 2646 mm     |  | 4  |
| 016365       | 68x68 mm    |   | 1  |
| 016692       | 1480 mm     |  | 1  |
| 016695       | 950 mm      |  | 2  |
| 016690       | 780x1525 mm |  | 1  |
| 013268       | 2790 mm     |  | 4  |

| art. nr./ref |            |  |     |
|--------------|------------|--|-----|
| 016785       | 1998 mm    |    | 4   |
| 016780       | 1484 mm    |    | 4   |
| 016368       | 104x104 mm |   | 1   |
| 016680       | 600 mm     |    | 4   |
| 016765       | 1647 mm    |   | 8   |
| 016770       | 369 mm     |   | 8   |
| 070600       | -          |   | 121 |
| 052916       | -          |    | 1   |
| 013609       | 2400 mm    |    | 6   |
| 016268       | -          |  | 1   |
| 016336       | -          |  | 2   |
| 013511       | 840 mm     |    | 2   |
| 013504       | 410 mm     |   | 4   |
| 016307       | -          |   | 1   |
|              |            | <ul style="list-style-type: none"> <li>+ divers bevestigingsmateriaal</li> <li>+ diverses Befestigungsmaterial</li> <li>+ matériel de fixation divers</li> <li>+ various fixing materials</li> <li>+ diverso materiale fissaggio</li> <li>+ Materiales de fijación diversos</li> </ul> |     |

# 1

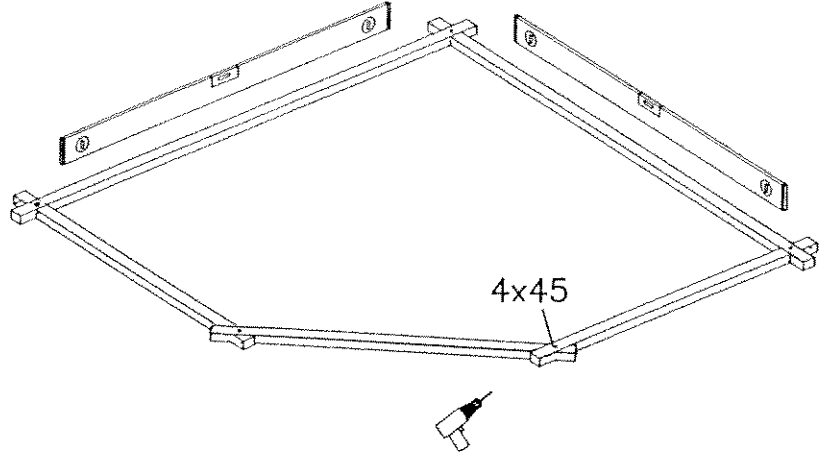
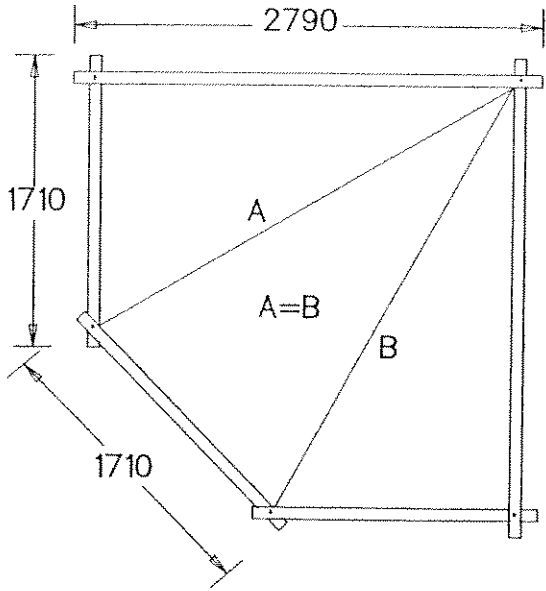

# 2

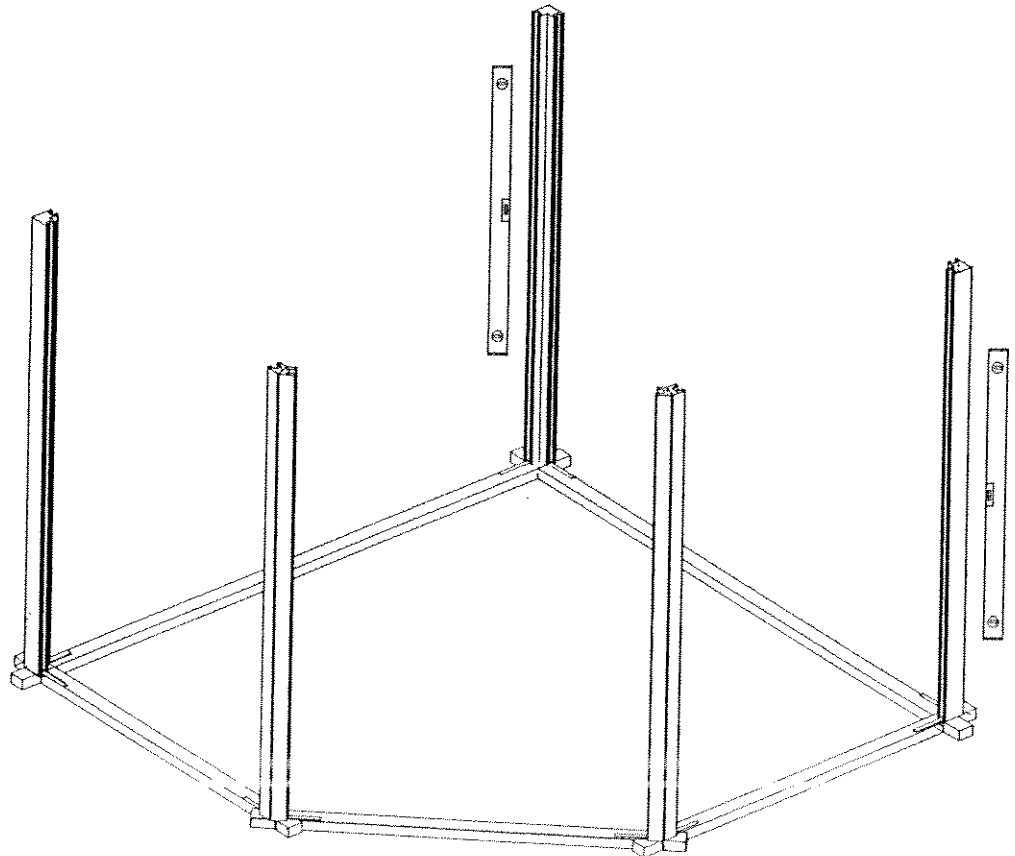
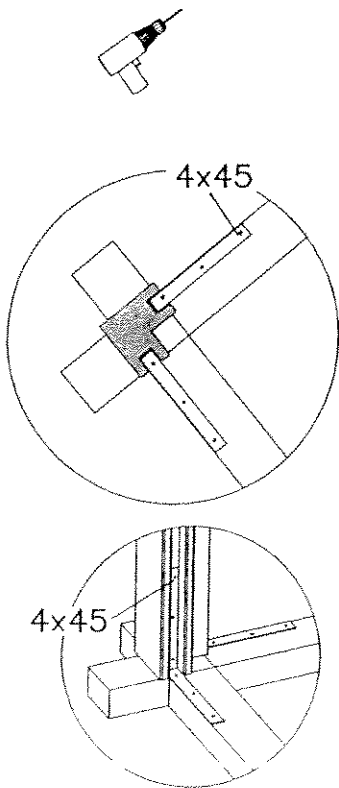

**3**

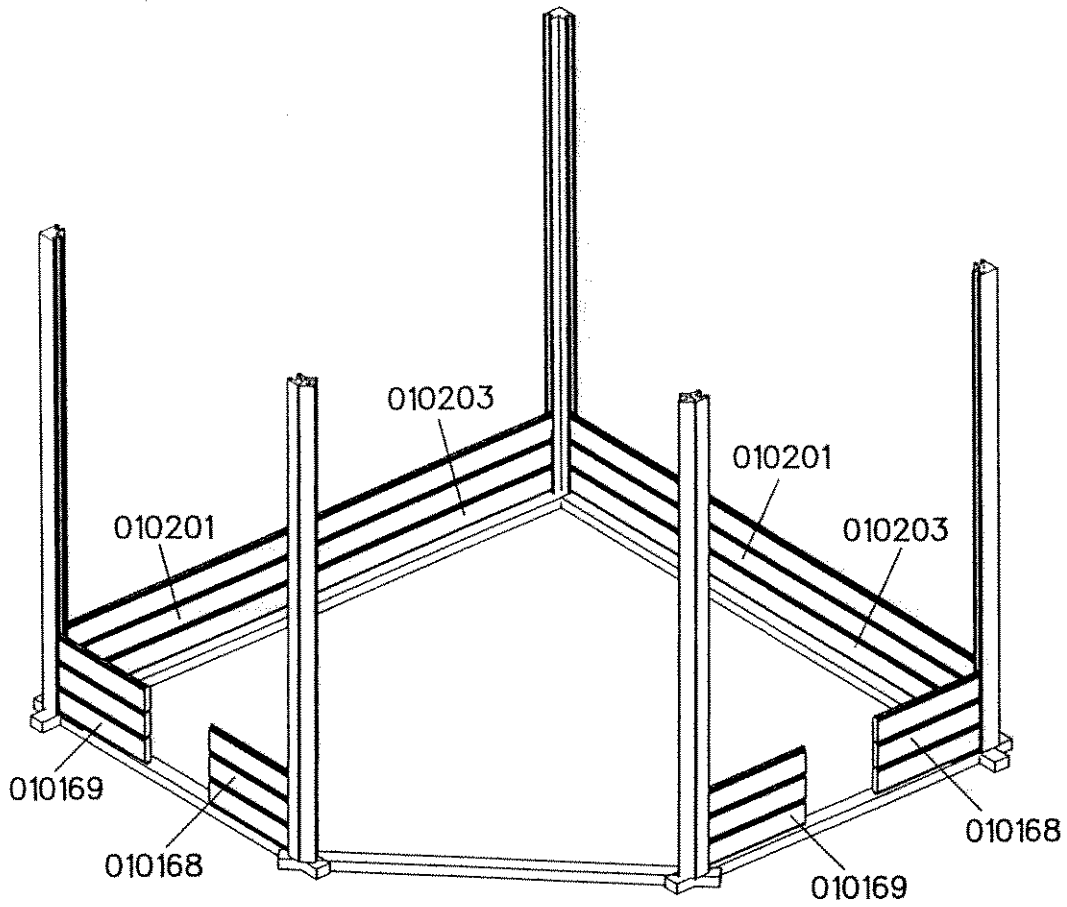

**4**

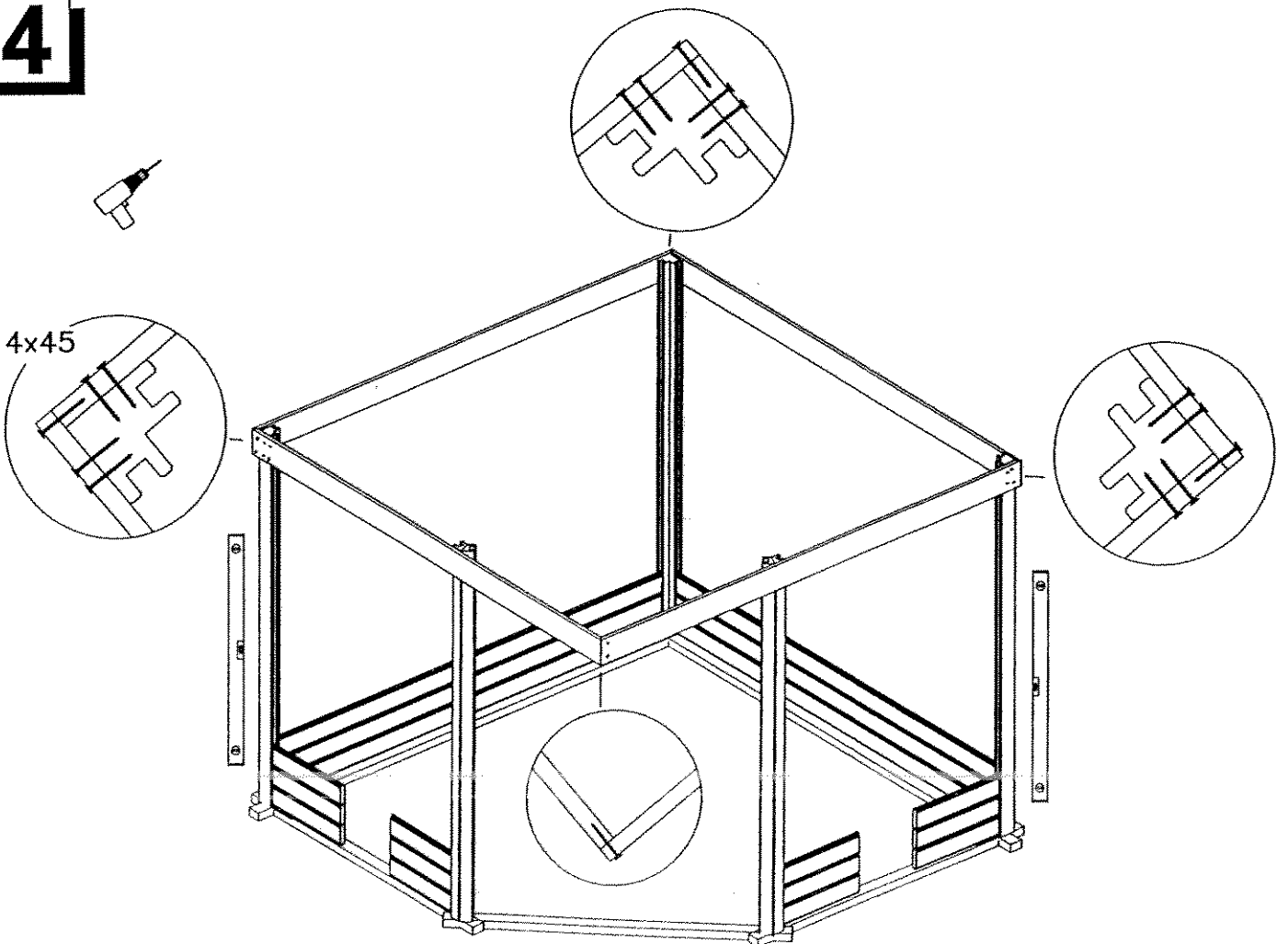

**5**

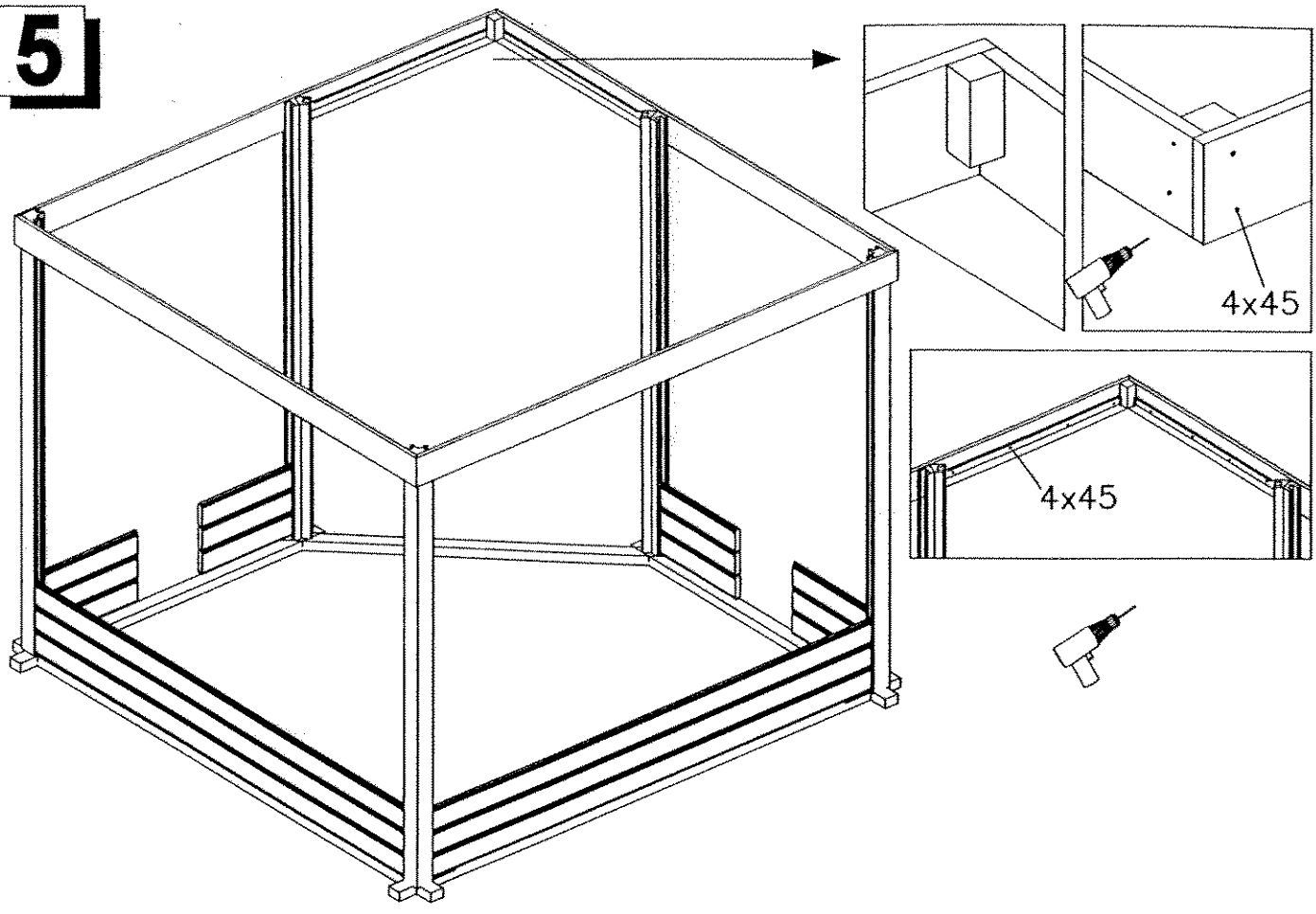

**6**

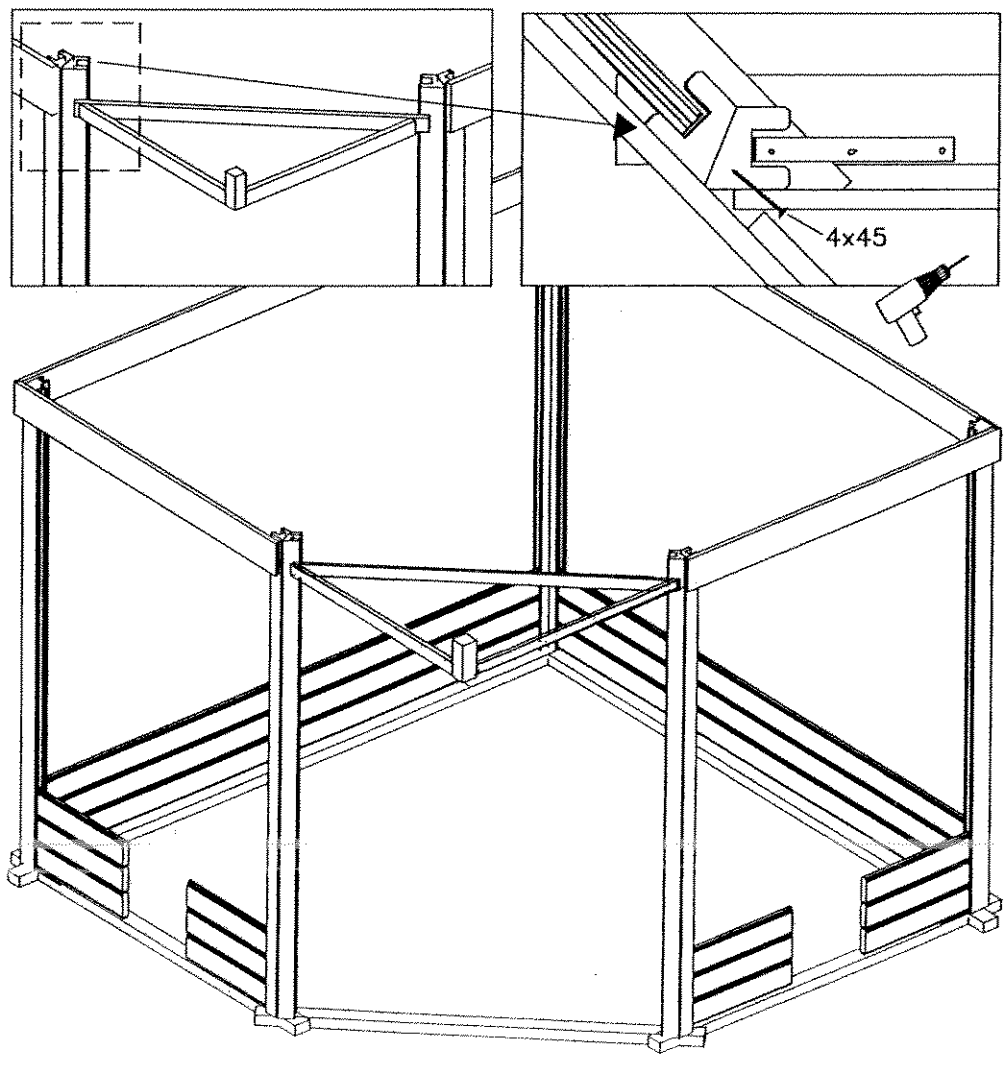

7

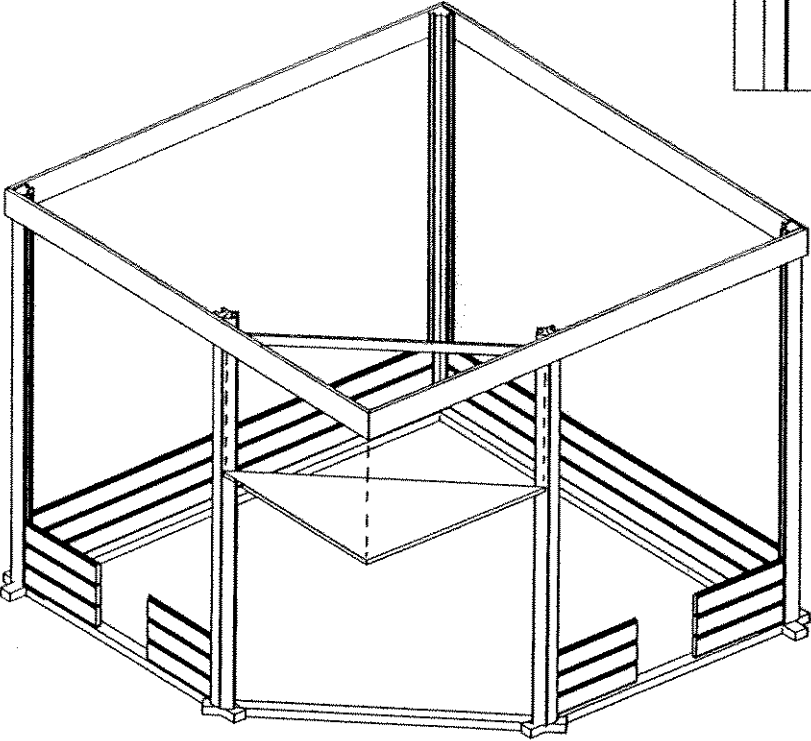
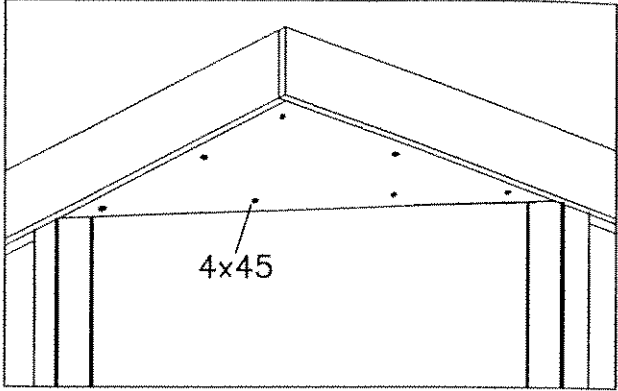

8

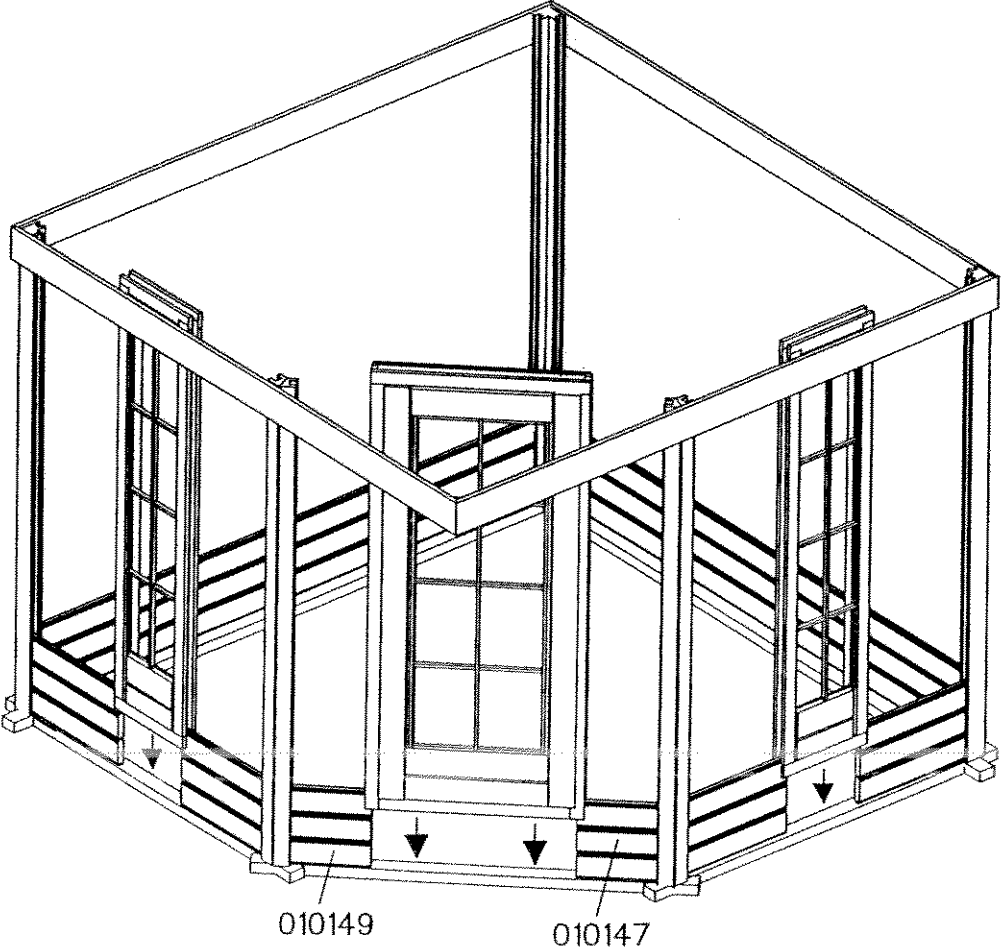

9

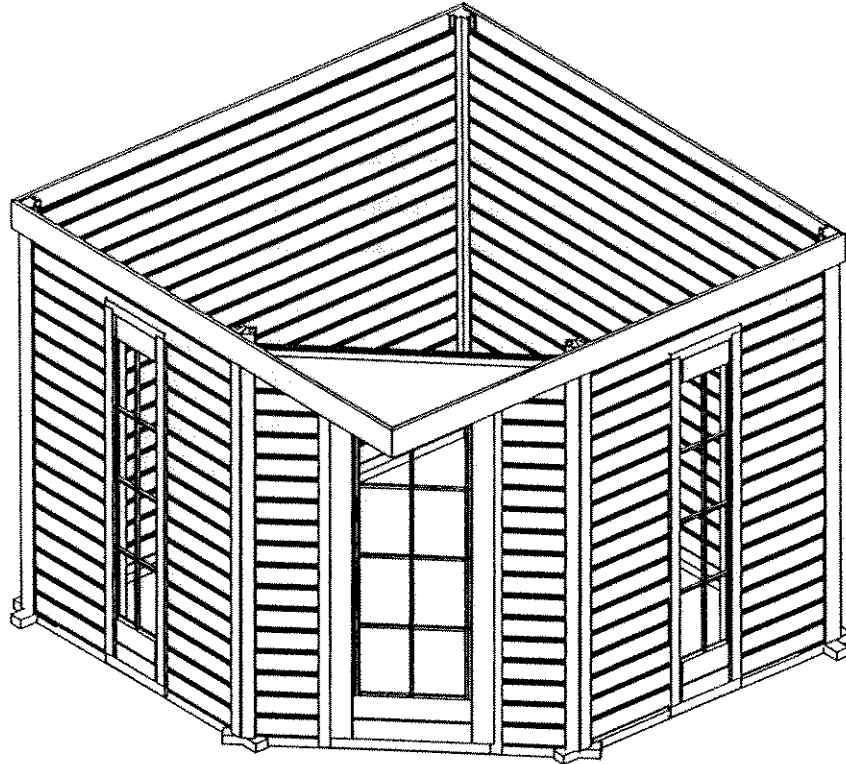
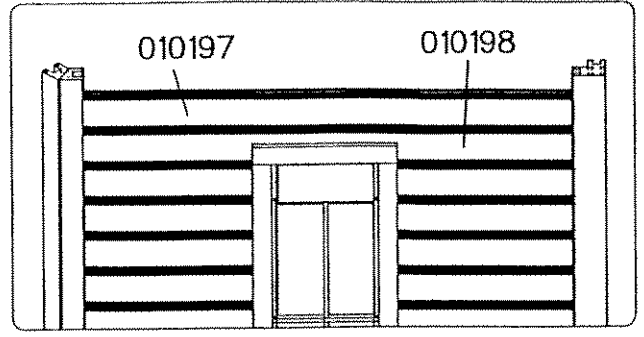
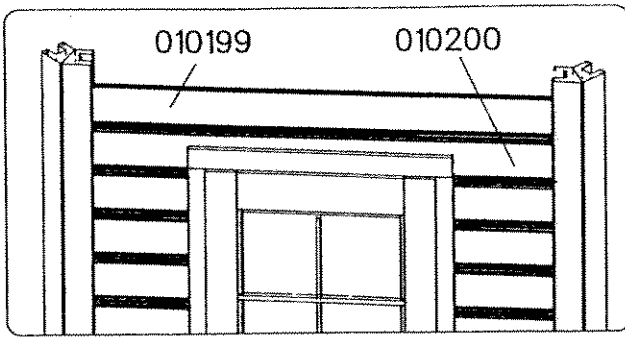

10

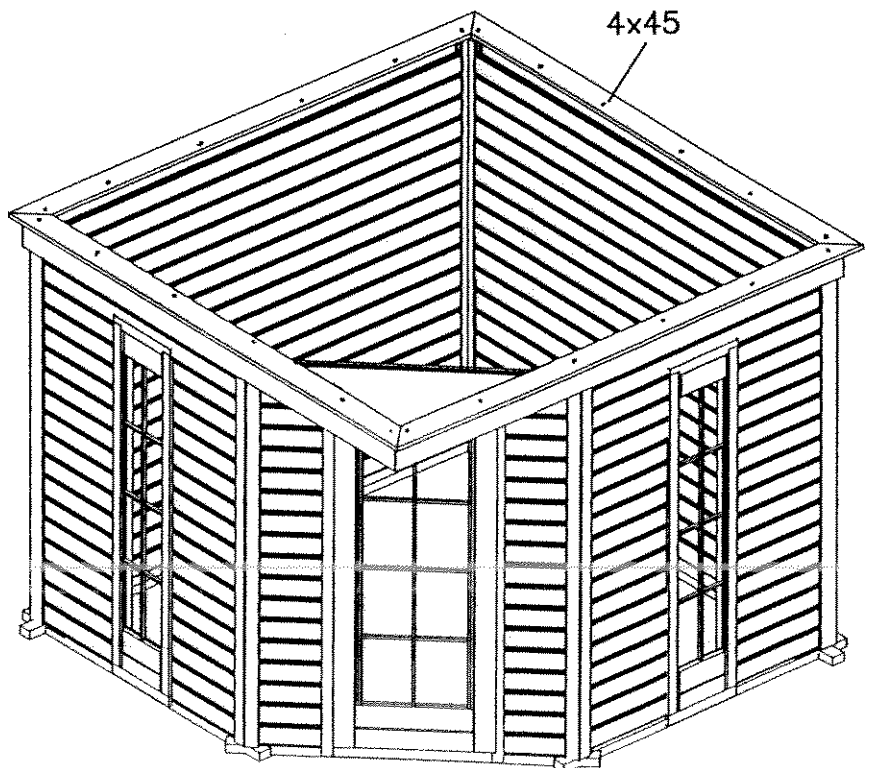
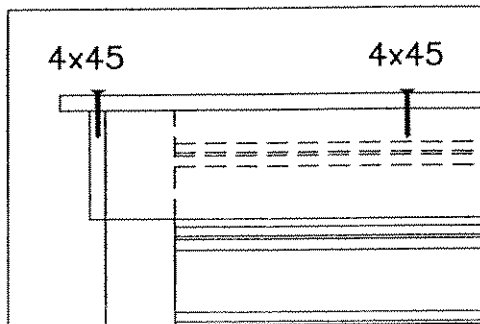

**11**

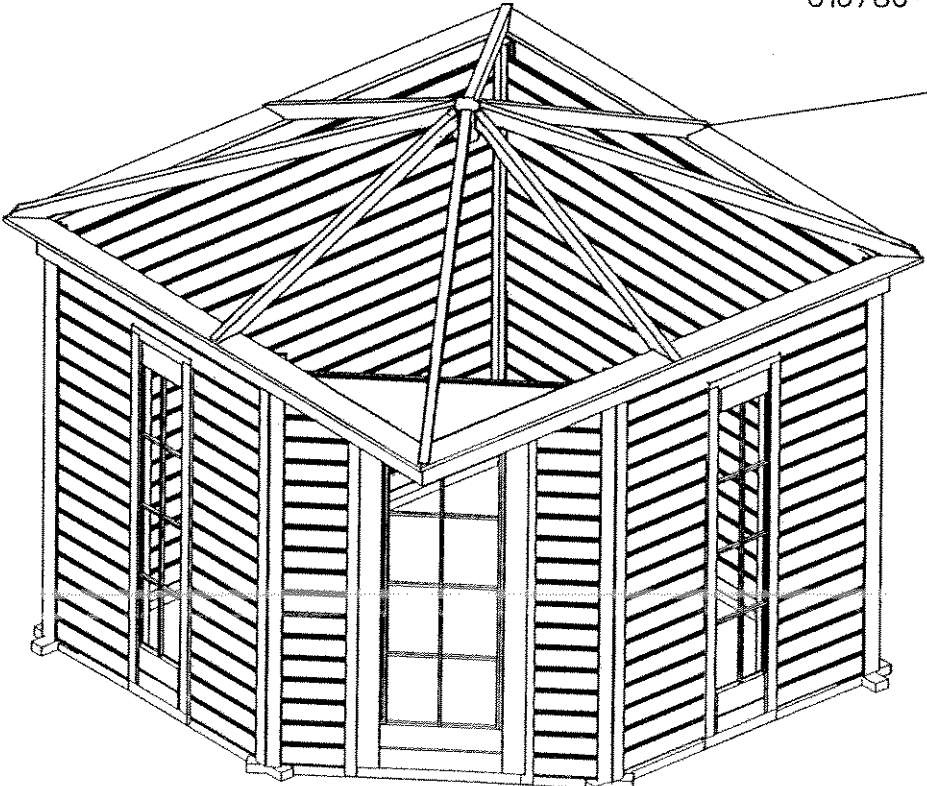
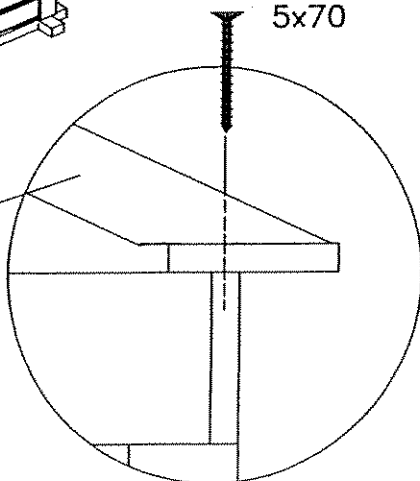
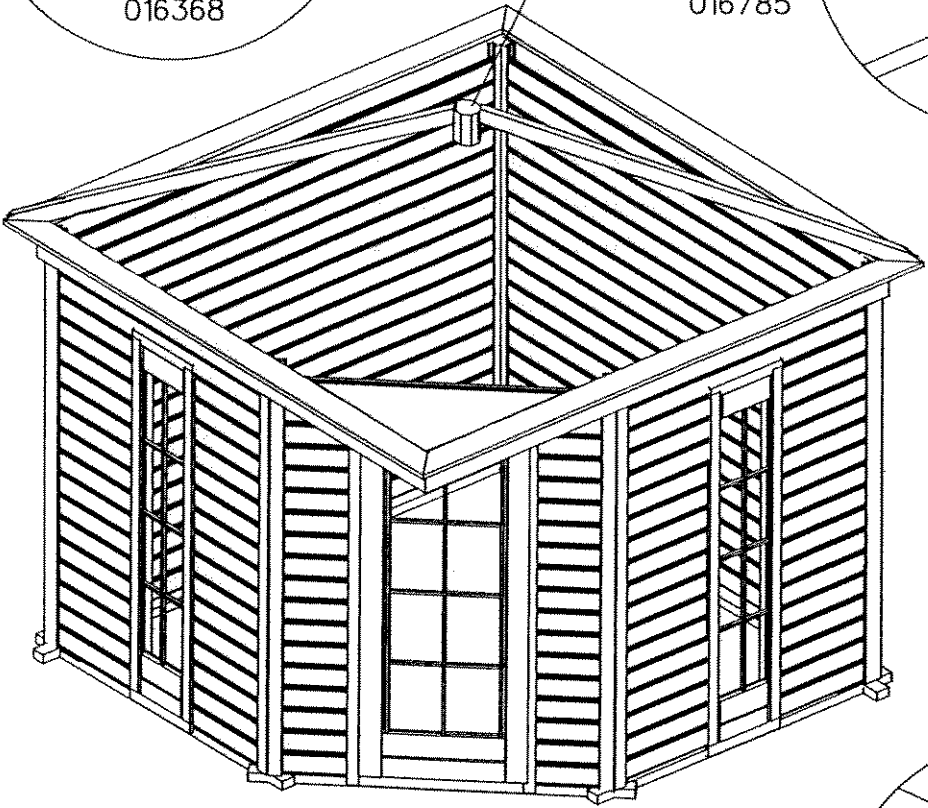
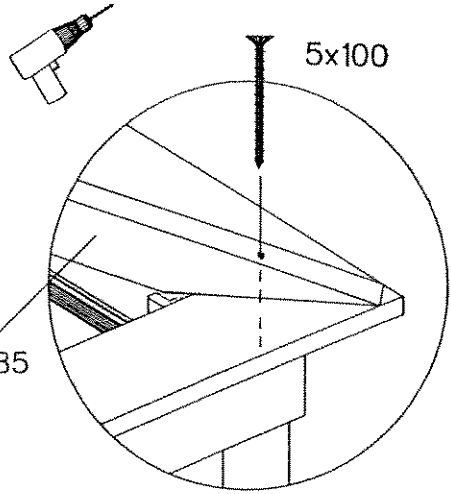
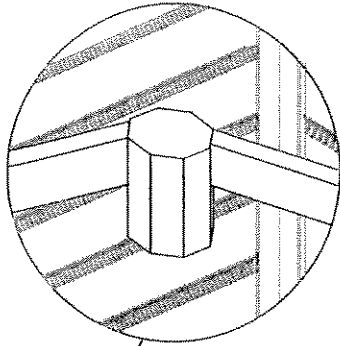
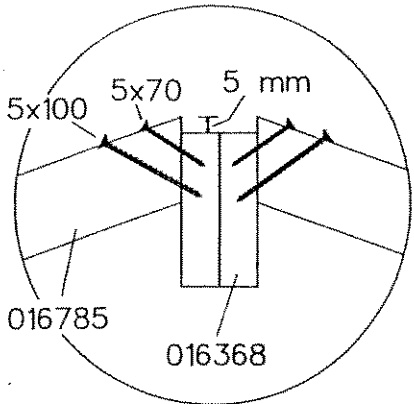

**12**

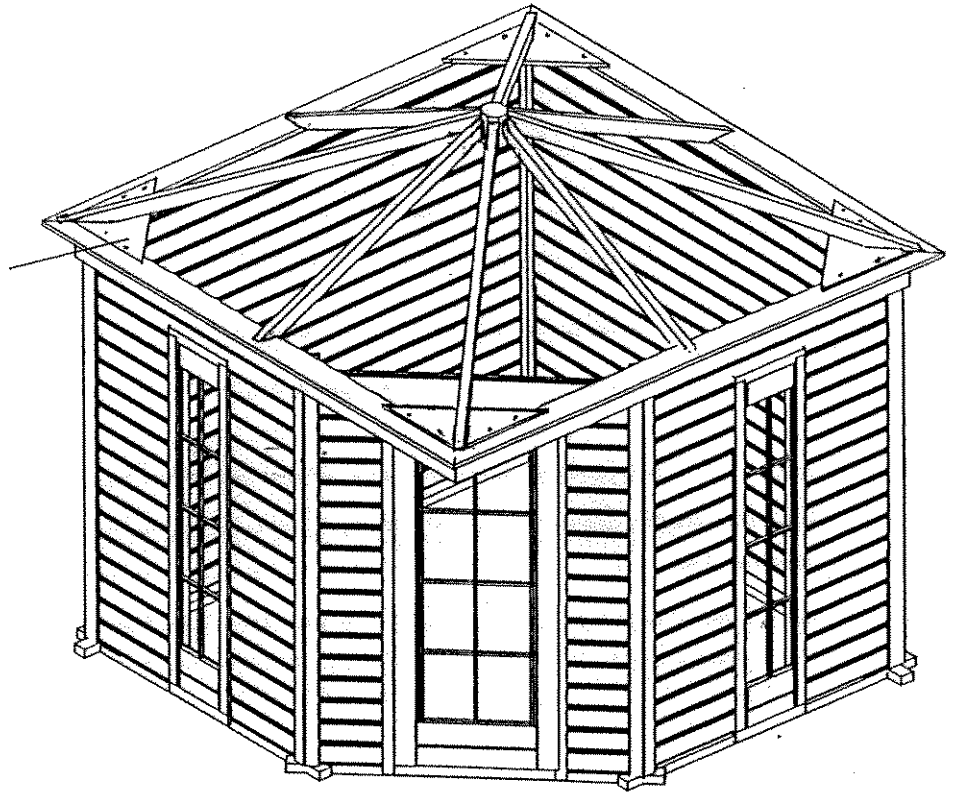
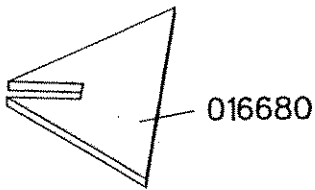
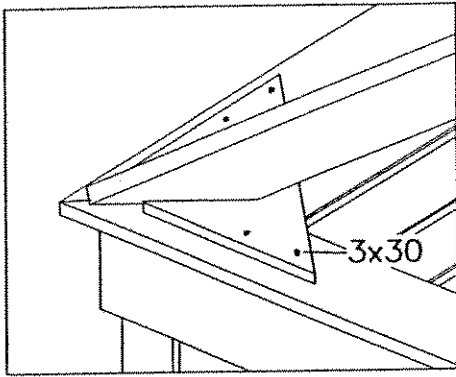

**13**

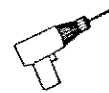
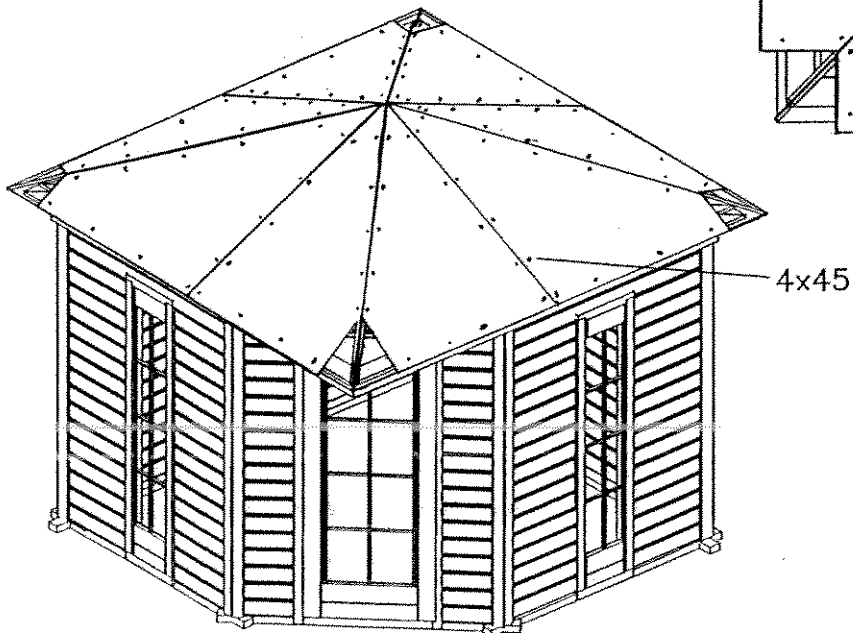
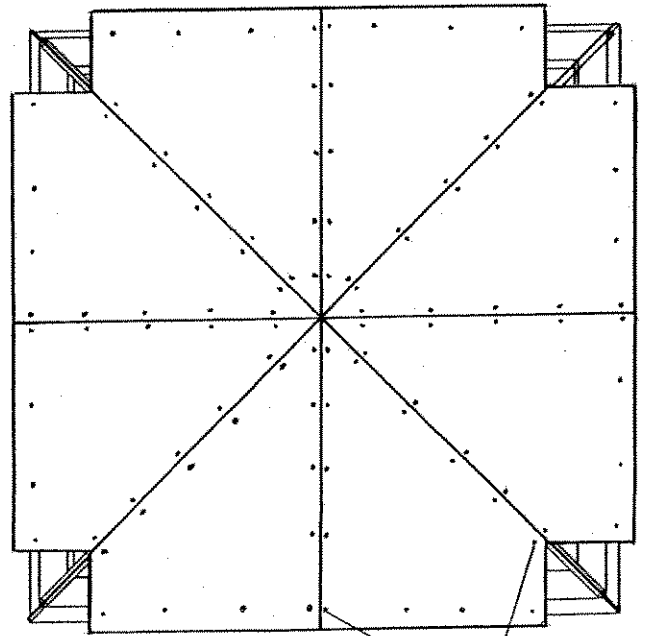

**14**

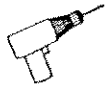

4x45

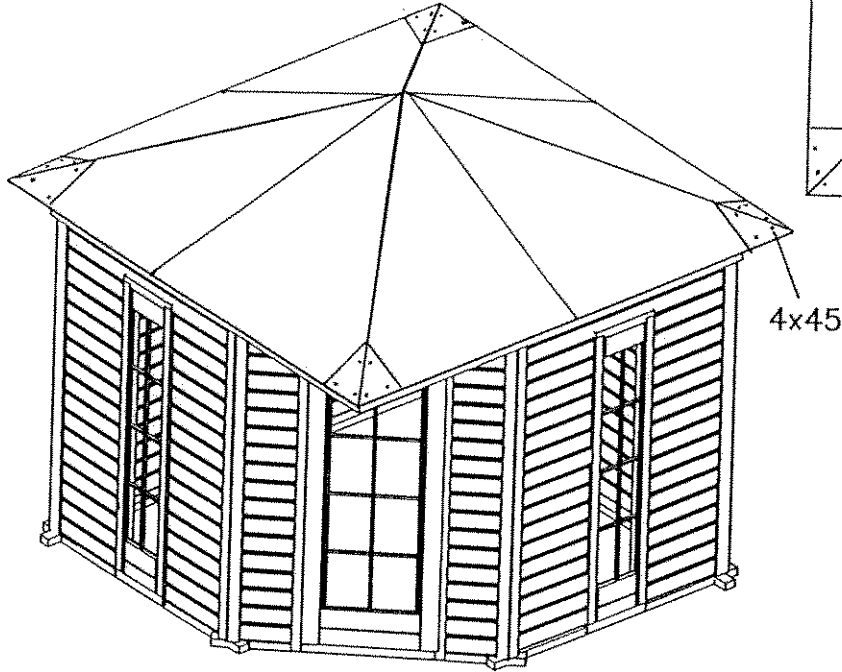
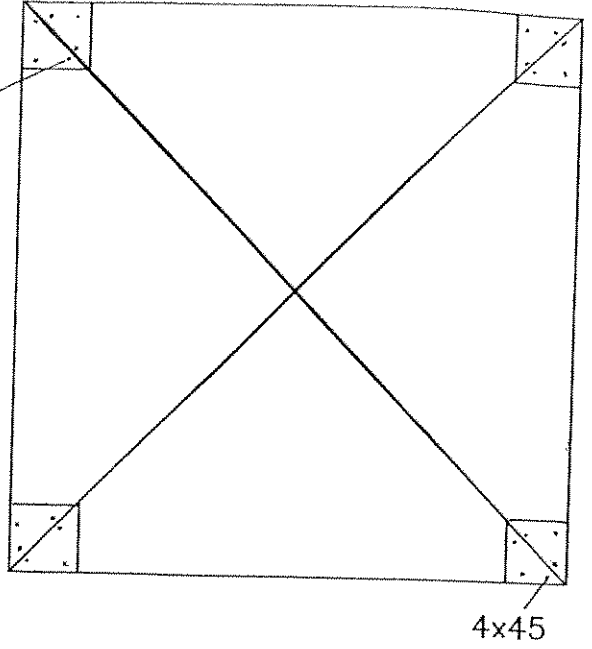

**15**

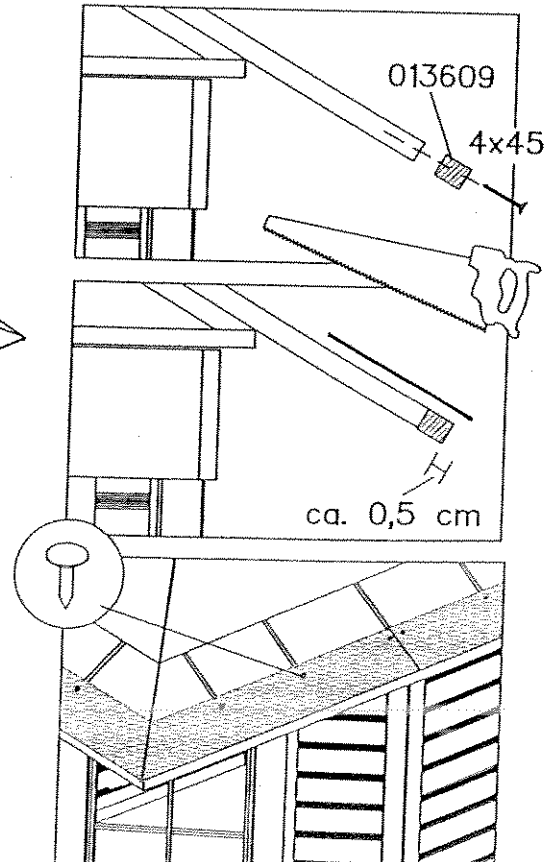
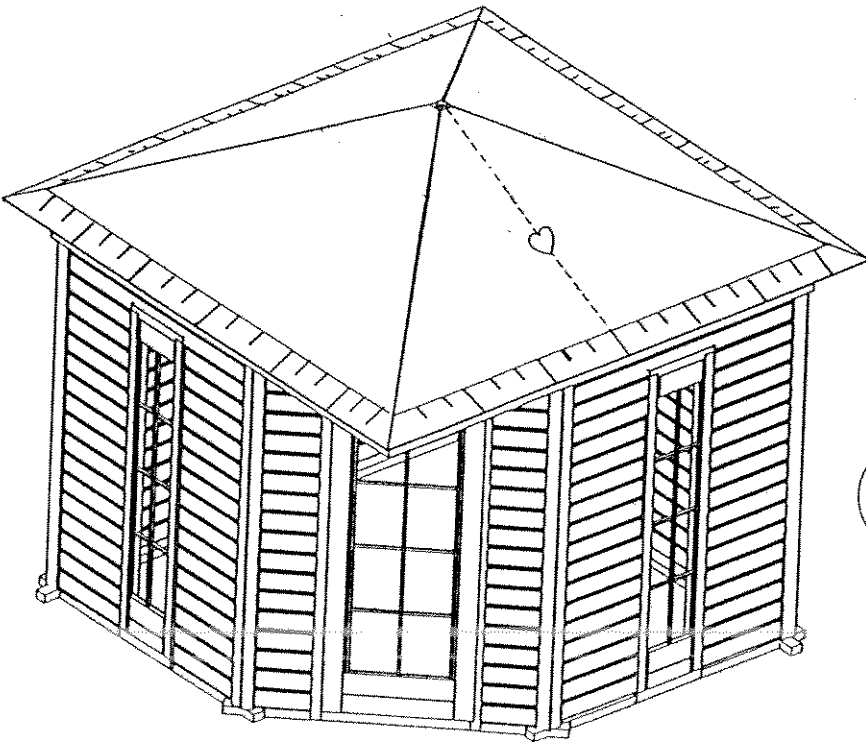

16

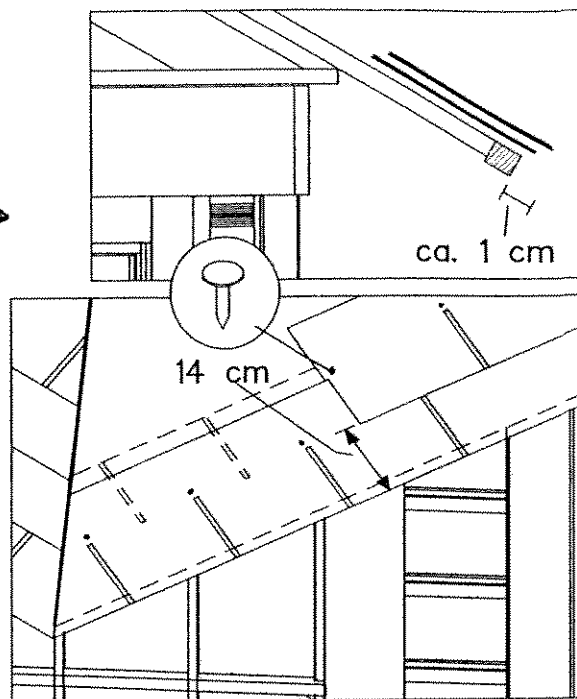
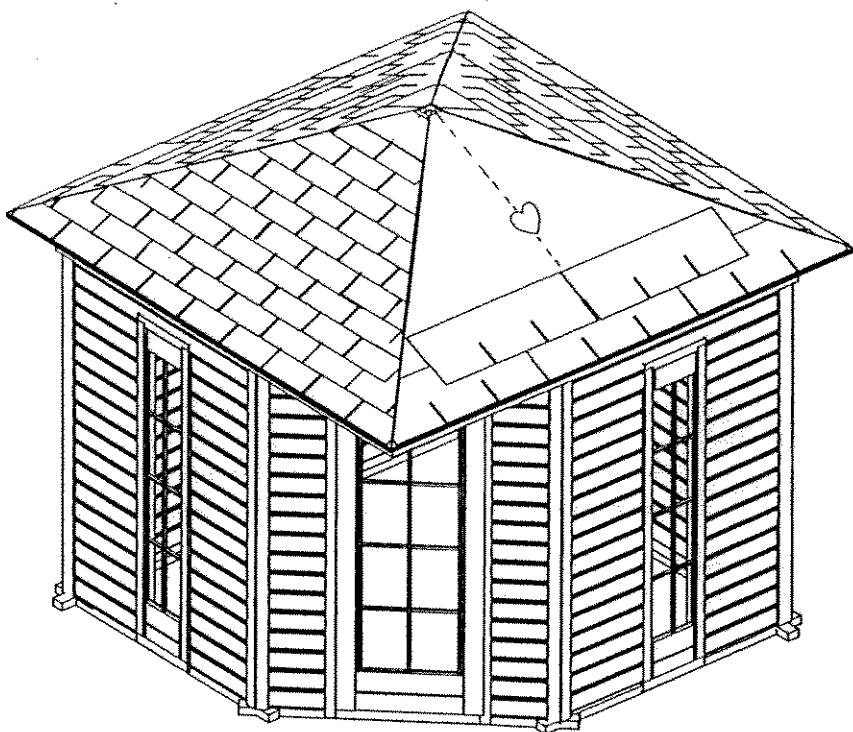

17

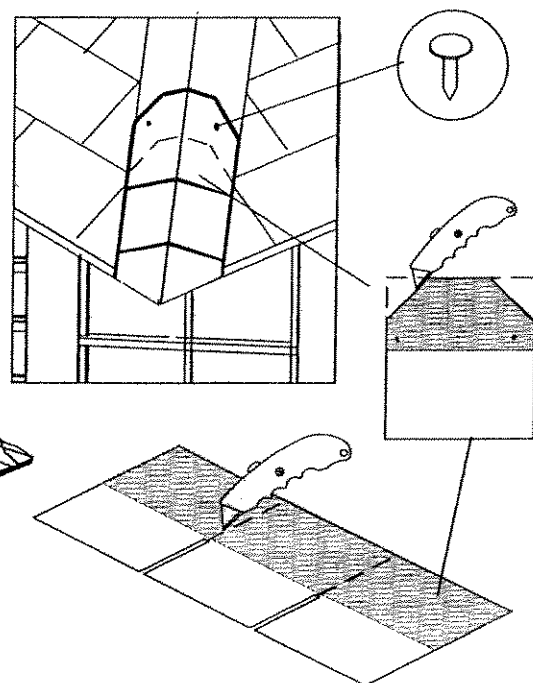
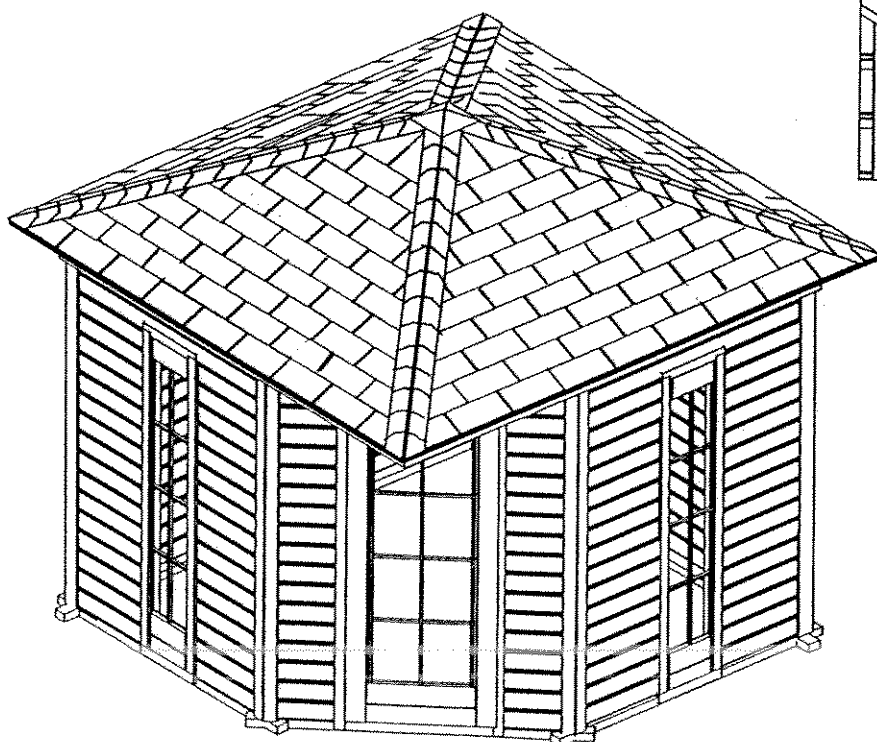

**18**

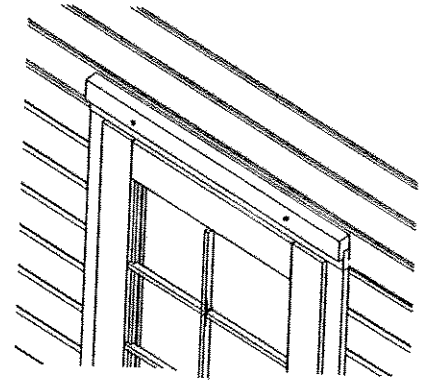
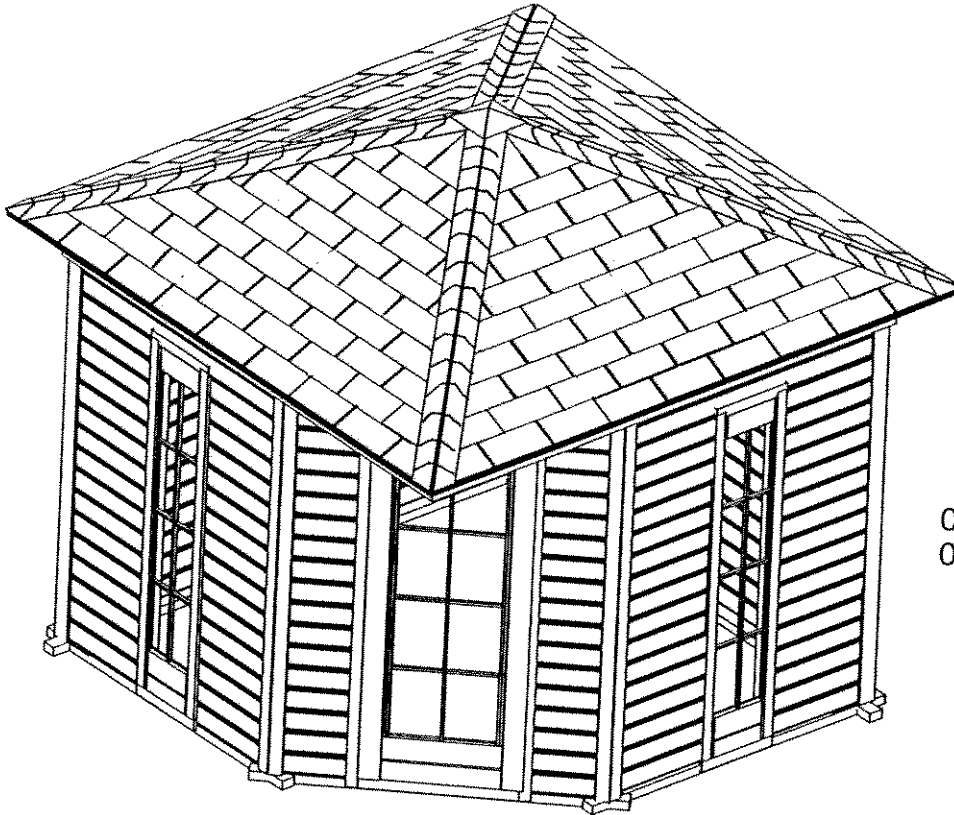
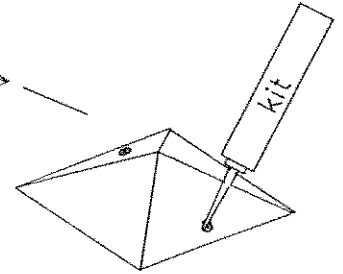
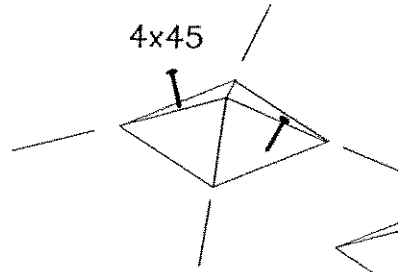
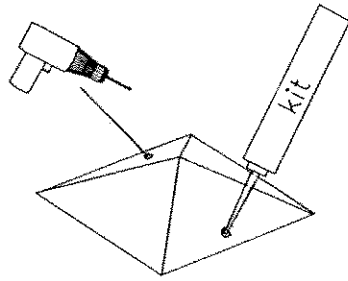

013511/  
013504

